

GS523DZ Tech Sheet

Balboa System PN 54763-01

System Model # GS5-GS523DZ-RCA-3.0

Software Version # 43

EPN # 2808

Base PCBA - PN 55857-01

PCB GS500Z - PN 22015 Rev B

Base Panels

VL801D (Serial Deluxe) – PN 54121

VL802D – PN 54562



System Revision History

System PN	EPN	Date	Requested By	Changes Made
54763-01	2808	02.10.2009	Balboa	Update software to version 43.
54763-01	2808	03.17.09	Balboa	Update Tech Sheet Electrical Service Config Pages

Basic System Features and Functions

Power Requirements

Single Service [3 wires (line, neutral, ground)]

- 230VAC, 50Hz, 1~, 32A, (Circuit Breaker rating = 40A max.)

Dual Service [5 wires (line 1, neutral 1, line 2, neutral 2, ground)]

- 230VAC, 50Hz, 1~, 2x 16A, (Circuit Breaker rating = 20A max each service.)

3-Phase Service [5 wires (line 1, line 2, line 3, neutral, ground)] **Requires PCB Rev B.**

- 400VAC, 50Hz, 3N~, 16A, (Circuit Breaker rating = 20A max each phase line.)
- **IMPORTANT** - Service must include a neutral wire, with a line to neutral voltage of 230VAC.

System Outputs

Setup 1 (As Manufactured)

- 230V Pump 1, 2-Speed
- 230V Pump 2, 1-Speed
- 230V Pump 3, 1-Speed
- 230V Blower
- 230V Ozone
- 10V Spa Light
- 230V AV (Stereo)
- 3.0kW Heater *

Setup 2

- 230V Pump 1, 2-Speed
- 230V Pump 2, 1-Speed
- 230V Pump 3, 1-Speed
- 230V Blower
- 230V Ozone
- 230V Circ Pump
- 10V Spa Light
- 230V AV (Stereo)
- 3.0kW Heater *

* Heater wattage is rated at 240V.

Additional Options

- Full Feature Dolphin Remote and Spa-only Dolphin Remote
- IR Receiver Module
Connects to terminal J1 or J2
(Must be 8-pin connector)
- MoodEFX Lighting
Connects to Spa Light terminal J20
- FiberEFX Lighting
Connects to Spa Light terminal J20

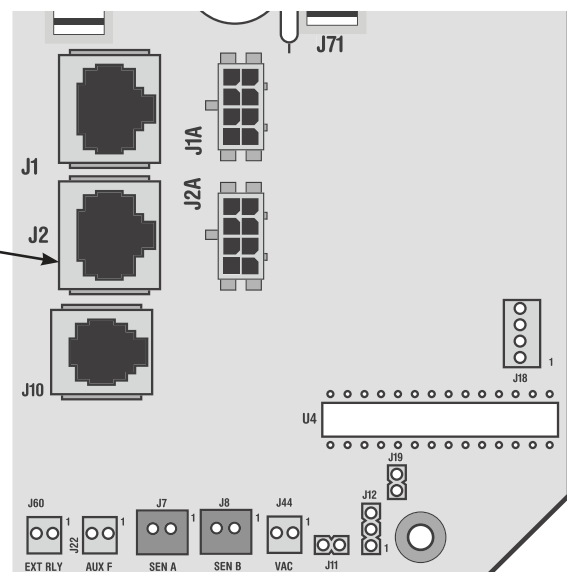

Basic System Features and Functions

Any time you change a DIP Switch, other than A1, you must reset Persistent Memory for your new DIP Switch Settings changes to take effect. If you do not reset Persistent Memory, your system may function improperly.

To reset Persistent Memory:

- Power down by disconnecting power source from spa.
- Put a jumper across J43, covering both pins. (See illustration below)
- Power up by connecting power source to spa.
- Wait until “P” is displayed on your panel.
- Power down again.
- Remove jumper from J43 (May also move to cover 1 pin only)
- Power up again.

About Persistent Memory and Time of Day Retention:

This system uses memory that doesn't require a battery to store a variety of settings. What we refer to as Persistent Memory stores the filter settings, the set temperature, and the heat mode.

Persistent Memory is not used for Time of Day. Only models with a Serial Deluxe panel installed (VS5xxDZ and GS5xxDZ) can display the time. However, during power loss to the spa, the system will lose the correct time, and reset to 12:00 PM when power is restored.

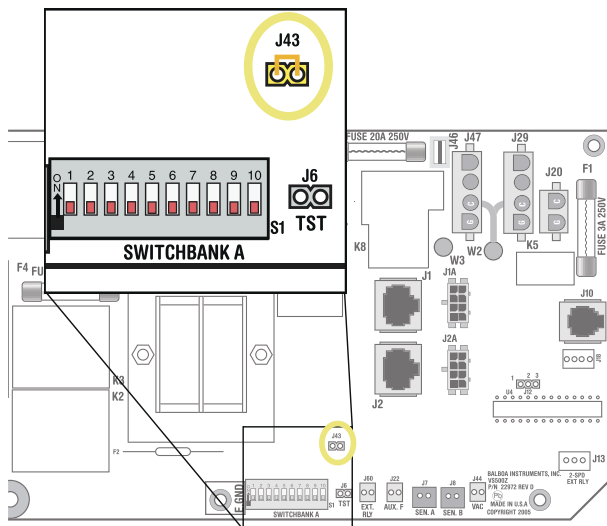

Wiring Configuration and DIP Settings

Setup 1 (As Manufactured)

- 230V Pump 1, 2-Speed
- 230V Pump 2, 1-Speed
- 230V Pump 3, 1-Speed
- 230V Blower
- 230V Ozone
- 10V Spa Light
- 230V AV (Stereo)
- 3.0kW Heater
- Deluxe Main Panel

HiPot Testing Note:

Disconnect slip terminal with green wires from J90 prior to performing HiPot test. Failure to disconnect may cause a false failure of the test. Reconnect terminal to J90 after successful completion of HiPot test.

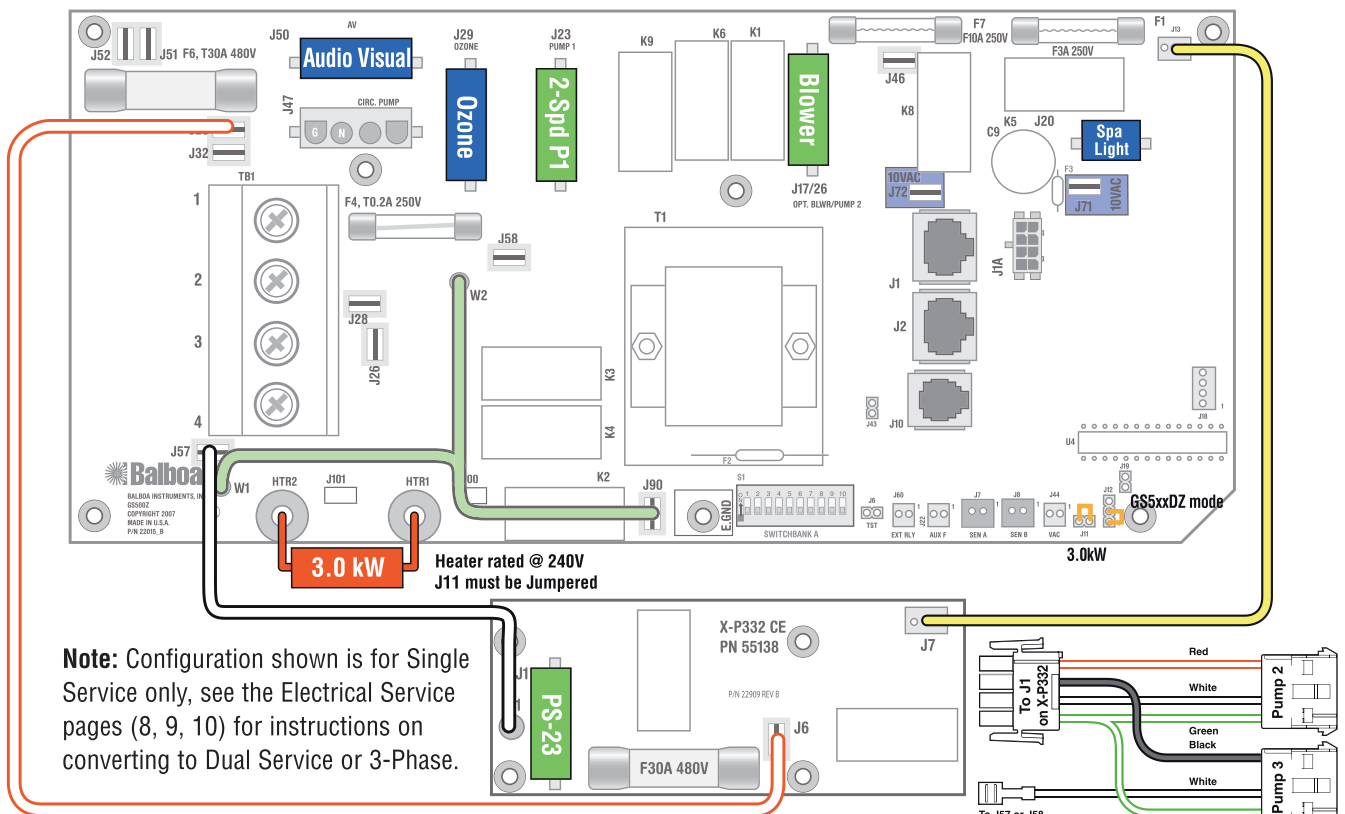

WARNING: Main Power to system should be turned OFF BEFORE adjusting DIP switches.

WARNING: Persistent Memory (J43) must be RESET to allow new DIP switch settings to take effect. (See Persistent Memory page)

SSID #

100
91
43

Switchbank A

A1, Test Mode OFF
A2, See Table 1
A3, N/A
A4, Aux Freeze
A5, 2-speed P1
A6, 50 Hz
A7, J17/26 Enabled
A8, Degrees C
A9, Non-Circ Mode
A10, See Table 1

GS523DZ Software

J11: 3.0kW Heater

J12: 3, 2, 1

J43: Memory Reset

Panel Button Assignments

1=Time	5=Light
2=Mode/Prog	6=Pump 1
3=Temp Up	7=Pump 2
4=Temp Down	8=J17/26

Panel Button Positions

Wiring Color Key

- Neutral (Common) AC Connections
- Special AC Connections
- Line AC Connections
- 10 Volt Connections
- Relay Control Wires

Board Connector Key

1: Typically Line voltage
2: Typically Line voltage for 2-speed pumps
3: Neutral (Common)
4: Ground

Note flat sides in connector

Wiring Configuration and DIP Settings

Setup 2

- 230V Pump 1, 2-Speed
- 230V Pump 2, 1-Speed
- 230V Pump 3, 1-Speed
- 230V Blower
- 230V Ozone
- 230V Circ Pump
- 10V Spa Light
- 230V AV (Stereo)
- 3.0kW Heater
- Deluxe Main Panel

HiPot Testing Note:

Disconnect slip terminal with green wires from J90 prior to performing HiPot test. Failure to disconnect may cause a false failure of the test. Reconnect terminal to J90 after successful completion of HiPot test.

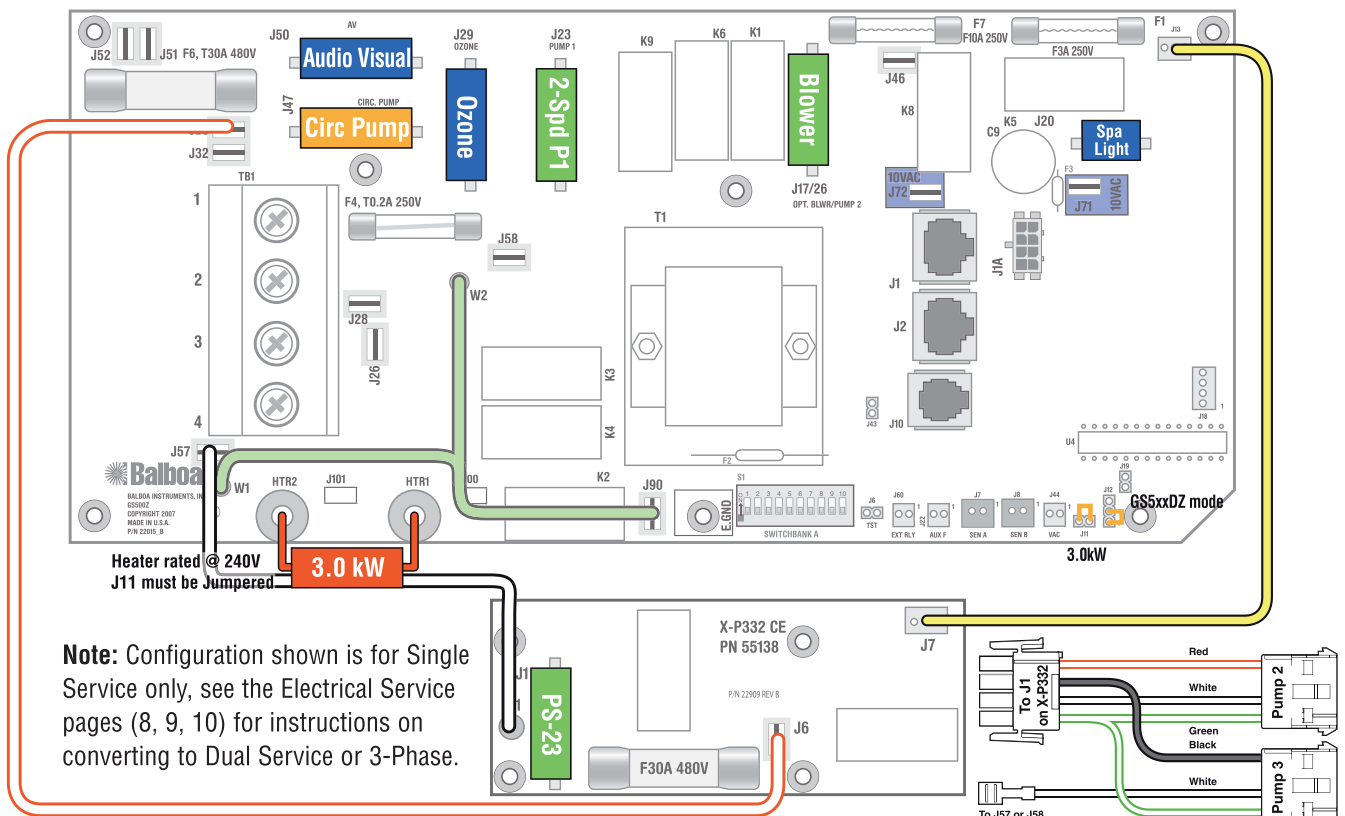

Note: Configuration shown is for Single Service only, see the Electrical Service pages (8, 9, 10) for instructions on converting to Dual Service or 3-Phase.

WARNING: Main Power to system should be turned OFF BEFORE adjusting DIP switches.

WARNING: Persistent Memory (J43) must be RESET to allow new DIP switch settings to take effect. (See Persistent Memory page)

SSID #

100
91
43

Switchbank A

A1, Test Mode OFF
A2, See Table 1
A3, N/A
A4, Aux Freeze
A5, 2-speed P1
A6, 50 Hz
A7, J17/26 Enabled
A8, Degrees C
A9, 24 Hour 3°F Circ Pump
A10, See Table 1

GS523DZ Software

J11 3.0kW Heater

J12 3, 2, 1

J43 Memory Reset

Panel Button Assignments

1=Time	5=Light
2=Mode/Prog	6=Pump 1
3=Temp Up	7=Pump 2
4=Temp Down	8=J17/26

Panel Button Positions

Wiring Color Key

- Neutral (Common) AC Connections
- Special AC Connections
- Line AC Connections
- 10 Volt Connections
- Relay Control Wires

Board Connector Key

1 Typically Line voltage
2 Typically Line voltage for 2-speed pumps
3 Neutral (Common)
4 Ground

Note flat sides in connector

DIP Switches and Jumpers Definitions

SSID 100 91 43

Base Model GS523DZ

DIP Switch Key

- A1 Test Mode (normally OFF)
- A2+A10 Control amp draw requirements (See Table 1)
- A3 N/A (must be OFF)
- A4 Aux Freeze (must be OFF)
- A5+A9 Pump 1 speeds and Circ Modes:

A5	A9	Circ Mode	Pump 1 Speed
OFF	OFF	Non-circ	2-speed
ON	OFF	Circ "acts like Pump 1 low" (filters/polls/ect)	1-speed
OFF	ON	24 hours with 3°F shut-off	1-speed
ON	ON	24 hours with 3°F shut-off	2-speed

- A6 "ON" position: 50Hz operation
"OFF" position: 60Hz operation
- A7 "ON" position: J17/26 Enabled for Blower or 1-speed Pump 4.
"OFF" position: J17/26 Disabled.
- A8 "ON" position: temperature is displayed in degrees Celsius
"OFF" position: temperature is displayed in degrees Fahrenheit

A2	A10	# of Hi-Speed Pumps/Blower Before Heat Disabled
OFF	OFF	0
ON	OFF	1
OFF	ON	2
ON	ON	3

Alert:

Pump 2 and Pump 3 are required, use X-P332 CE expander board with PS-23 splitter cable. To add Blower or 1-speed Pump 4, use J17/26.

Jumper Key

- J11** If using 3kW or higher wattage heater, jumper can be set in either position, but may perform better on Pins 1 and 2. If using 2.5kW or lower wattage heater, jumper must be set on 1 Pin only.
- J12** **Factory set. DO NOT MOVE.**
Jumper must be on Pins 1 and 2 for GS51xZ/GS52xZ/GS5xxSZ/GS5xxDZ software.
Jumper must be on Pins 2 and 3 for GS50xZ software.
- J43** When jumper is placed on 2 pins during power-up, system will reset persistent memory. Leave on 1 pin only to enable persistent memory feature.

WARNING:

- Setting DIP switches incorrectly may cause abnormal system behavior and/or damage to system components.
- Refer to Switchbank illustration on Wiring Configuration page for correct settings for this system.
- Contact Balboa if you require additional configuration pages added to this tech sheet.

Panel Button Positions

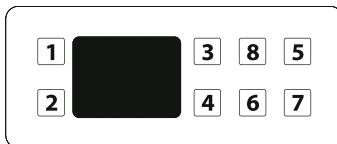

Panel Button Assignments

- 1=Time
- 2=Mode/Prog
- 3=Temp Up
- 4=Temp Down
- 5=Light
- 6=Pump 1
- 7=Pump 2+Pump 3
- 8=J17/26 (when A7 is ON)

Aux Panel Information

Supports 2-button aux panel



Supports 4-button aux panel



Electrical Service Configuration Options

Systems with PCB Rev B Only

AS MANUFACTURED

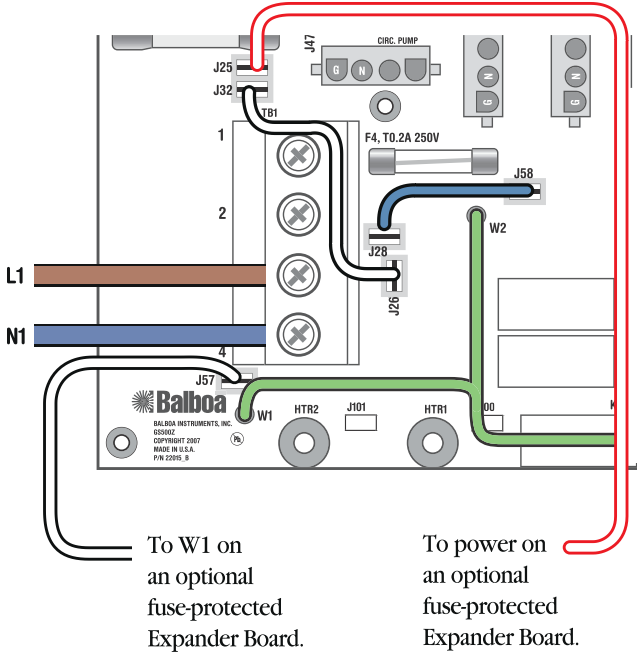

Single Service, TN and TT Electrical Systems (1 x 32 Amp)

3 Wires (1 Line + 1 Neutral + 1 Protective Earth)
 Protective Earth wire (Green/Yellow) must be connected to system ground terminal as marked.

This option is configured and shipped as the default.

All equipment (pumps, blower, heater and any expander board) runs on service line L1.

Systems using only 1 DIP switch (A10) for heat disable:
 1 x 16 Amp Service is not supported:
 For 1 x 32 Amp Service:
 Set DIP Switch A10 such that total system amperage draw never exceeds rated service input.
 Systems using multiple DIP switches for heat disable:
 Refer to system Hot Sheet DIP Switch Definition page and set the switches shown in Table 1 such that total system amperage draw never exceeds rated service input.

OPTIONAL

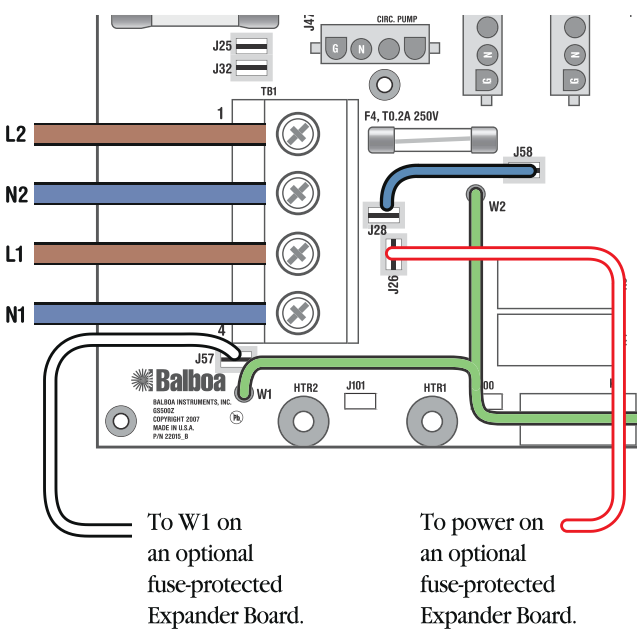

Dual Service, TN and TT Electrical Systems (2 x 16 Amp)

5 Wires (2 Lines + 2 Neutrals + 1 Protective Earth)
 Protective Earth wire (Green/Yellow) must be connected to system ground terminal as marked.

The heater and any expander board run on service line L1, while all other equipment, such as pumps and blowers, run on service line L2.

Completely remove the white wire from J26 and J32.
 Note: J32 and J25 are electrically identical. The white wire may be attached to either terminal before removal.

Systems using only 1 DIP switch (A10) for heat disable:
 DIP Switch A10 must be OFF.
 Systems using multiple DIP switches for heat disable:
 Refer to system Hot Sheet DIP Switch Definition page and set both switches shown in Table 1 to ON positions.

If using an Expander Board:
 Systems using multiple DIP switches for heat disable:
 Refer to system Hot Sheet DIP Switch Definition page and set both switches shown in Table 1 to OFF positions.

Electrical Service Configuration Options

Systems with PCB Rev B Only

OPTIONAL

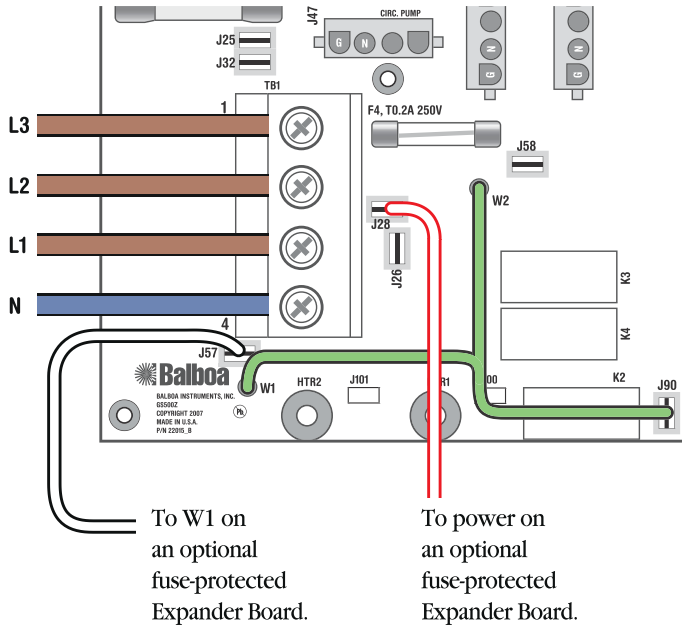

3-Phase Service, TN and TT Electrical Systems 5 Wires (3 Lines + 1 Neutral + 1 Protective Earth)

Protective Earth wire (Green/Yellow) must be connected to system ground terminal as marked.

IMPORTANT - Service **MUST** include a neutral wire, with a line to neutral voltage of 230VAC.

The heater runs on service line L1.

*All main-board equipment run on service line L3.
Additional equipment, such as expansion boards, run on service line L2.*

Completely remove the white wire from J26 and J32, or J25.
Completely remove the blue wire from J28 and J58.

Systems using only 1 DIP switch (A10) for heat disable:
DIP Switch A10 must be OFF.

Systems using multiple DIP switches for heat disable:
Refer to system Hot Sheet DIP Switch Definition page and set both switches shown in Table 1 to ON positions.

NOTE:

- Not all GS5xxZ systems can support 3-Phase.
- 3-Phase requires System PCB Rev B.
- If using an expansion board, the board must have fuse-protection.

Electrical Service Application Notes

*This page is specific to the GS523DZ model with 7A max pumps.
(The preceding pages cover all possible GS applications.)*

As manufactured, this system comes configured for Single Service.
See the preceding pages for instructions on moving wires for Dual Service or Three-Phase configurations.

Use the following guidelines for setting DIP Switches appropriately for the particular service configuration chosen.

For 1x16A Service:

Not Supported.

For 1x32A Service:

Switch A2 must be OFF and A10 can be ON.

For 2x16A Service:

Switches A2 and A10 must be OFF (because Pumps 2 and 3 are on the same service as the Heater).

For 3-phase Service (16A per phase):

Pump 1 and blower are on one phase, Pumps 2 and 3 are on another phase, and the Heater is on its own phase. So there are no limitations needed on equipment running together. Thus switches A2 and A10 can both be ON.

Ozone Connections

Note: A special tool is required to remove the pins from the connector body once they are snapped in place. Check with your Balboa Account Manager for information on purchasing a pin-removal tool.

Balboa Ozone connector configuration for 230VAC 50Hz:

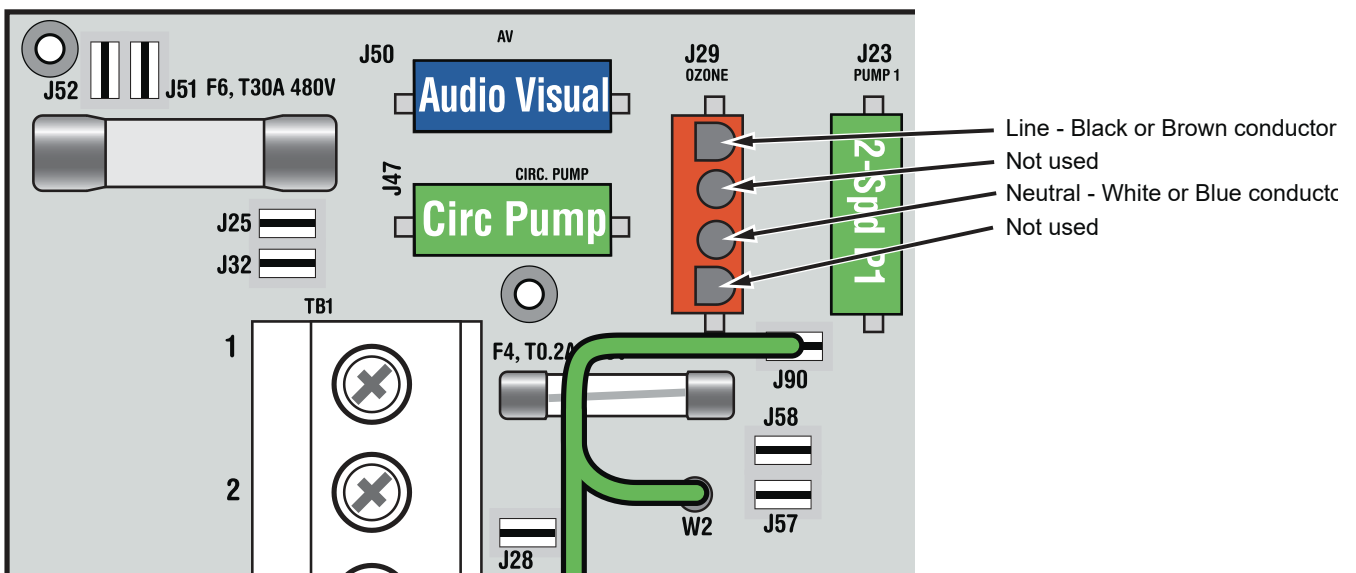
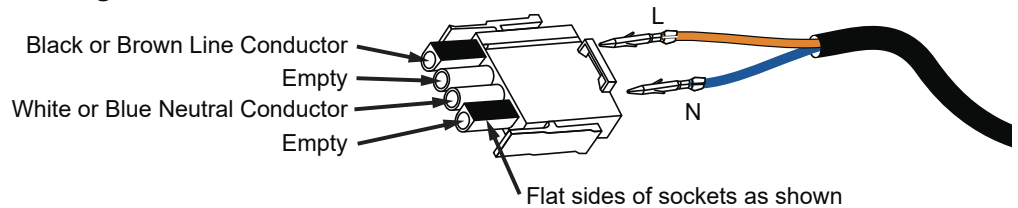

Serial Deluxe Panel Configurations

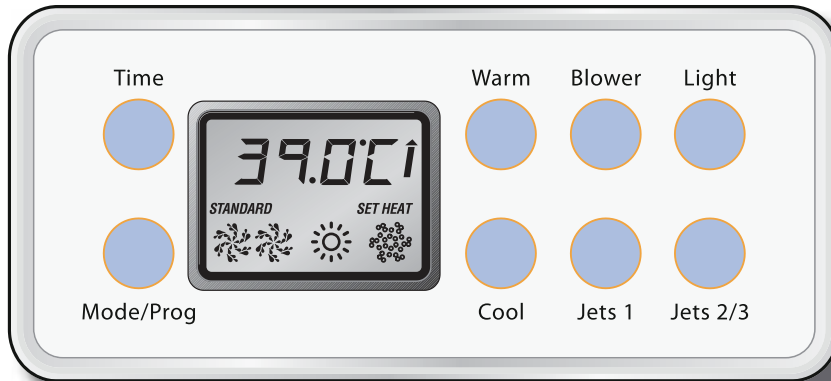

VL801D (Serial Deluxe)

PN 54121 no Overlay

- Connects to Main Board terminal J1 only*

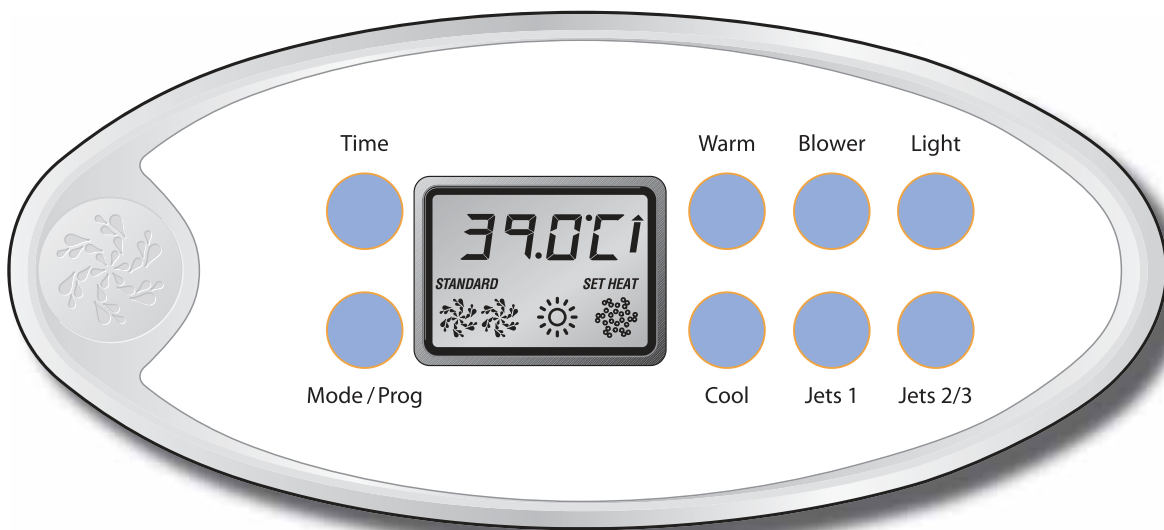

VL802D

PN 54562 no Overlay

- Connects to Main Board terminal J1 only*

* Panels with back-lighting (bulbs installed) should never be plugged into J2. Use J1 only.
If the backlight bulbs are removed, then both J1 and J2 may be used.